

**PIVOT PANEL QUAD (PPQ) LOOSE TILE DISPLAY  
4-SIDED SPINNER**

**ORDER #PPQ**

ACCEPTS 44 SAMPLES FROM 9" WIDE UP TO 15" AND 1/2" THICK  
(CAN REDESIGN TO ACCEPT MORE OR LARGER)

SPINS/ROTATES (GREAT FUNCTION IF YOU PUT IN CORNER)

STURDY STEEL UPPER FRAME, POWDERCOATED TEXTURE BLACK

DURABLE MDF BASE WITH BALL-BEARING "LAZY SUSAN"

WE CAN SCREEN PRINT THE BASE TO IDENTIFY THE DISPLAY  
AS YOUR PROPERTY

SIMPLE ASSEMBLY ONLY REQUIRING A BOX END WRENCH



**TOP VIEW SHOWS 30" DIAMETER**

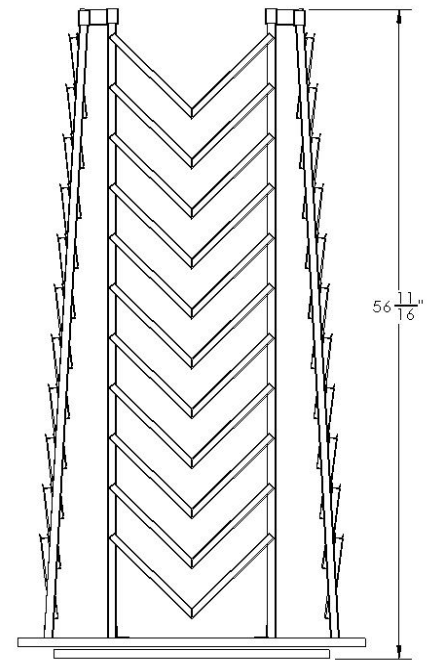
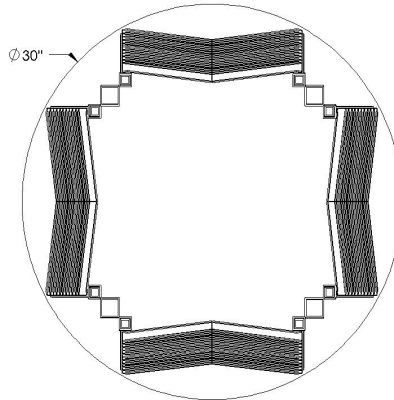
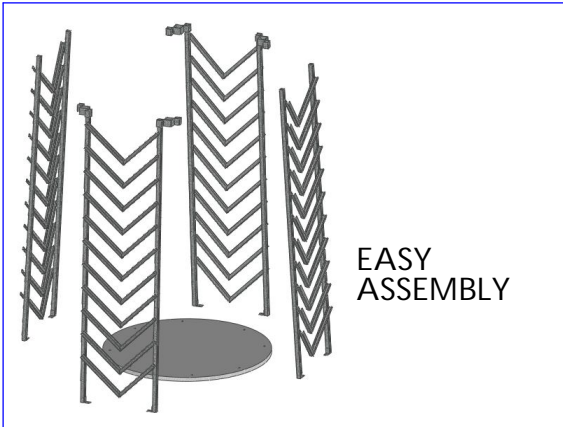

We took the lazy-susan off the dinner table and put vertical columns of "v" channels on it so your customers can "pivot" through more of your tile products in a smaller footprint. Take advantage of that wasted floor space in the corner of your showroom, the pivot function of this tile display allows the customer to spin through more of your products to find that perfect tile for their application. The very strong steel tube and sheet-metal structure of this line of displays can display ceramic tile, marble tile, granite tile, stone, carpet sample boards, bathroom tiles, glass tiles, pavers, hardwoods, laminates, etc. The channels position the substrates at 45 degrees for a dynamic attention-getting appearance that will draw your customers in. The "Pivot Panel" tile display is a bolt together unit and requires only a box end wrench. To assemble, simply position the individual columns on the base unit and screw down into the predrilled/threaded holes. There are only five elements comprising the main structural components allowing the disassembled unit to be packed and shipped in a small package (reducing your shipping cost.) The simple assembly means you can set-up, stock and start selling your products asap! Accepts square products from 9" x 9" up to 15" x 15" and thicknesses up to 1/2". Standard powder-coated colors are white and black. Custom colors also available. The best thing about ThomasRECOM is our ability to respond so keep in mind that all these pre-engineered designs can be easily modified to fit almost any substrate you want to display. Call us today at 1-800-973-2660.

WE CAN MAKE THIS DISPLAY IN MANY DIFFERENT  
SIZES, CONTACT US TO SEE HOW!