

Back

DOUBLE 10-COUNT (HOLDS 20 SAMPLES) WATERFALL PLANK DISPLAY

ORDER# DBL10CFSWHT

QTY: (QTY 1-10) PACKED 1/CTN: **\$56.25/DISPLAY**
QTY: (QTY 11-74) PACKED 1/CTN: **\$47.50/DISPLAY**
QTY: (QTY 75-149) PACKED 1/CTN: **\$46.25/DISPLAY**
QTY: (QTY 150 +) PACKED 1/CTN: **\$43.75/DISPLAY**

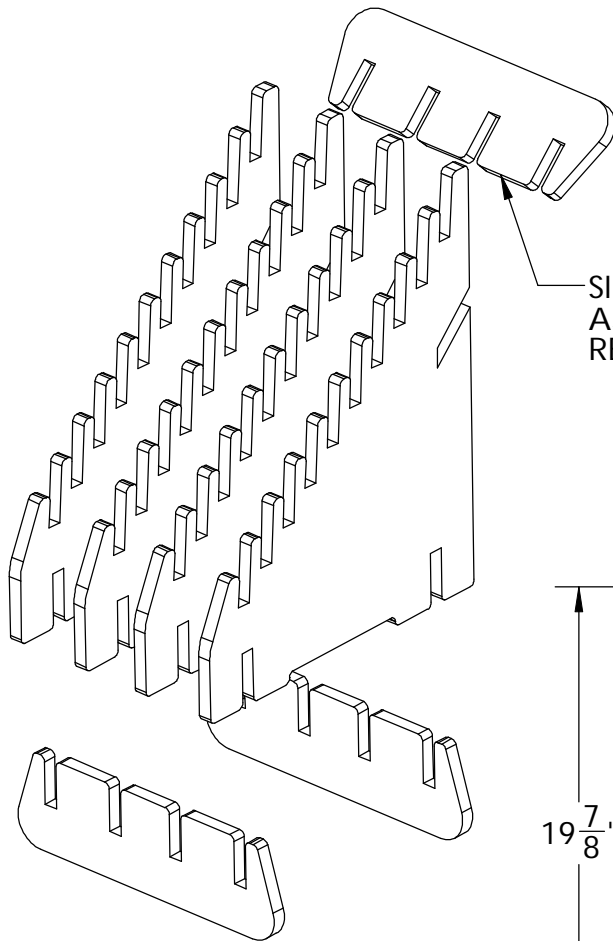

SIMPLE "SLIP-TOGETHER"
ASSEMBLY (NO TOOLS
REQUIRED)

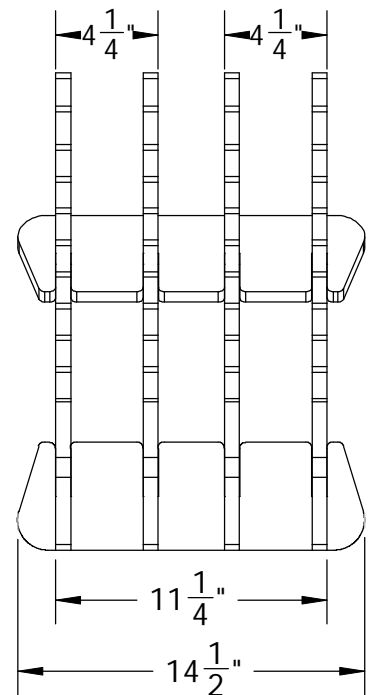
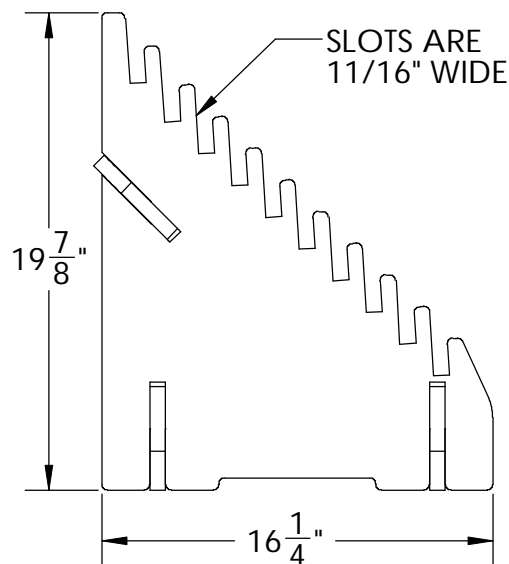

HOLDS 20 SAMPLES
MINIMUM PLANK WIDTH: 5"
MAXIMUM PLANK WIDTH: 6"
OR YOU CAN SPAN ACROSS THE FULL WIDTH WITH
A 12" OR LARGER SAMPLE
STANDARD WHITE WITH WHITE PAINTED EDGES
OTHER COLORS ARE AVAILABLE
MAXIMUM TILE THICKNESS IS 5/8"
WE CAN MAKE OTHER SIZE SLOTS
FOOTPRINT: 14-1/2" WIDE X 16-1/4" DEEP X 20" TALL
WEIGHT 18 LBS
BOXED UPS 23"X19"X5" 20LBS 1/CTN

THOMAS RECOM
THE THOMAS RESEARCH COMPANY INC.
1-800-973-2660 WWW.ThomasRECOM.COM

1-800-973-2660
www.ThomasRECOM.com
EMAIL: Mike@ThomasRECOM.com
714 Concordia Blvd. Pensacola, FL 32505

