

Back

DOUBLE 10-COUNT (HOLDS 20 SAMPLES) WATERFALL PLANK DISPLAY

ORDER# DBL10CFSBLK

QTY: (QTY 1-10) PACKED 1/CTN: **\$56.25/DISPLAY**

QTY: (QTY 11-74) PACKED 1/CTN: **\$47.50/DISPLAY**

QTY: (QTY 75-149) PACKED 1/CTN: **\$46.25/DISPLAY**

QTY: (QTY 150+) PACKED 1/CTN: **\$43.75/DISPLAY**

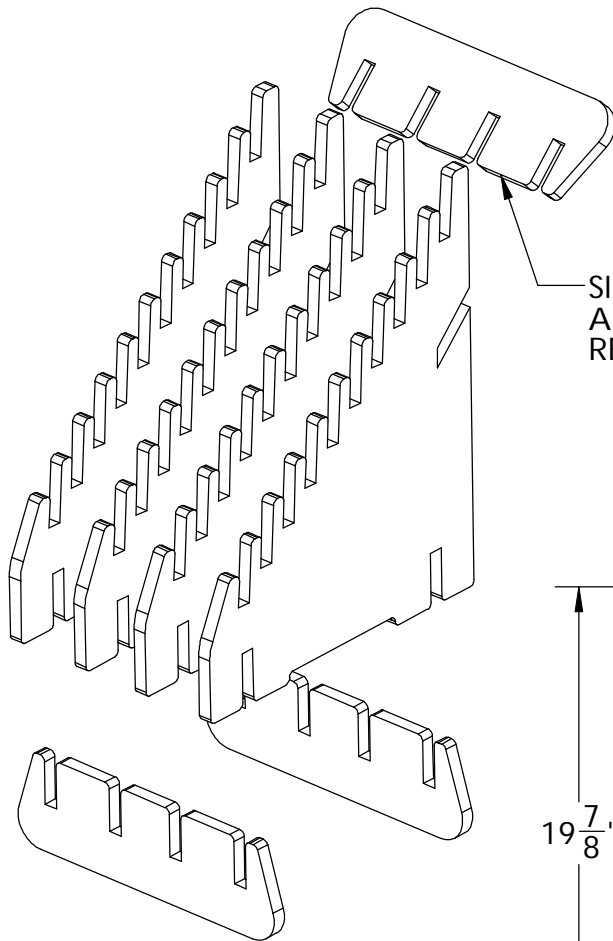
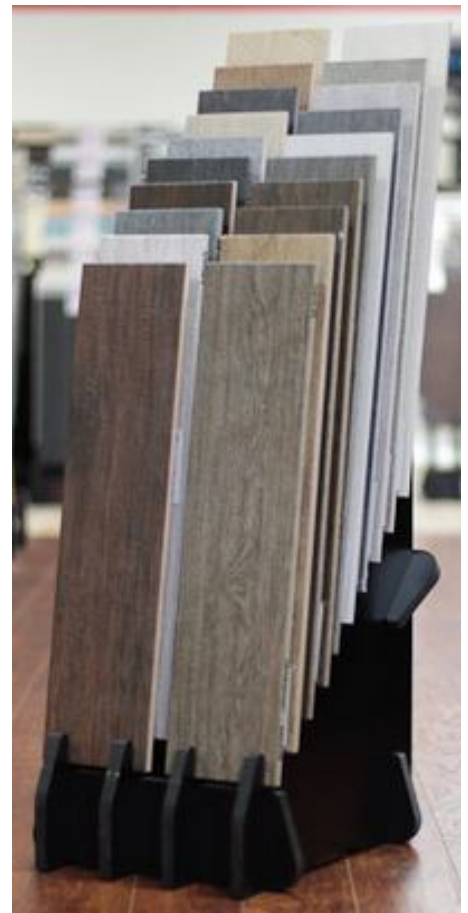

SIMPLE "SLIP-TOGETHER"
ASSEMBLY (NO TOOLS
REQUIRED)

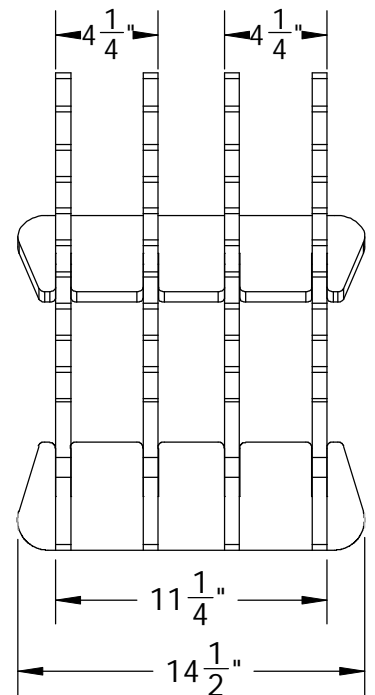
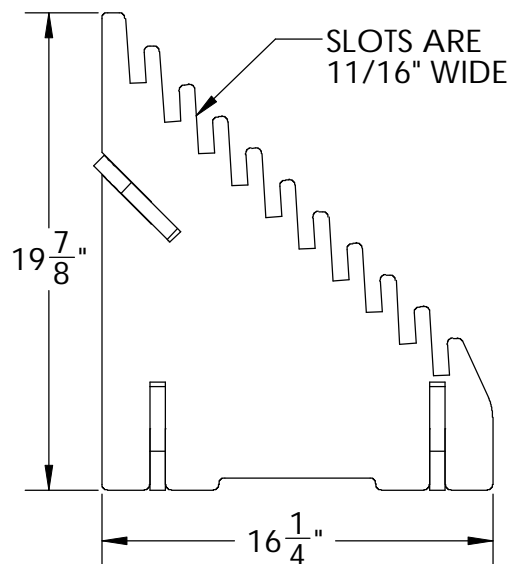

HOLDS 20 SAMPLES
MINIMUM PLANK WIDTH: 5"
MAXIMUM PLANK WIDTH: 6"
OR YOU CAN SPAN ACROSS THE FULL WIDTH
WITH A 12" OR LARGER SAMPLE
STANDARD BLACK WITH BLACK PAINTED EDGES
OTHER COLORS ARE AVAILABLE
MAXIMUM TILE THICKNESS IS 5/8"
WE CAN MAKE OTHER SIZE SLOTS
FOOTPRINT: 14-1/2" WIDE X 16-1/4" DEEP X 20" TALL
WEIGHT 18 LBS
UPS BOX 23"X19"X5" 20LBS 1/CTN



1-800-973-2660

www.ThomasRECOM.com

EMAIL: Mike@ThomasRECOM.com

714 Concordia Blvd. Pensacola, FL 32505

