

9 COUNT STAGGERED WATERFALL DISPLAY
HOLDS (9) SAMPLES
(WHITE) ORDER# 9CS1596
DALTILE PART #9999481802

QTY: (5-9) PACKED 1/CTN **\$97.97/EACH**
 QTY: (10-19) PACKED 1/CTN **\$72.53/EACH**
 QTY: (20-49) PACKED 1/CTN **\$59.99/EACH**
 QTY: (50+) PACKED 1/CTN **\$47.81/EACH**

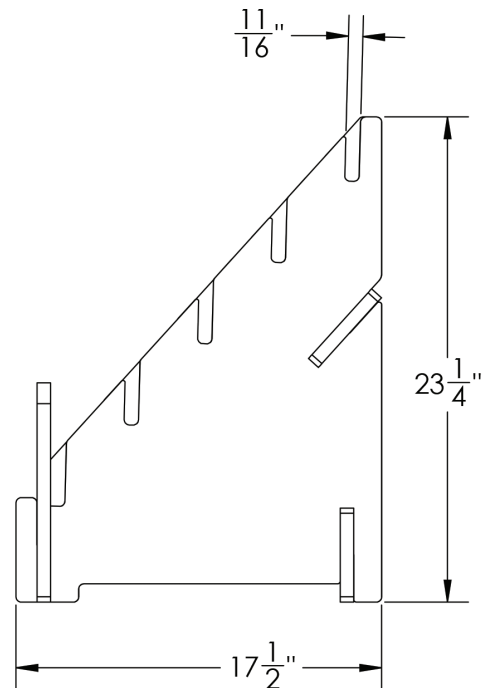
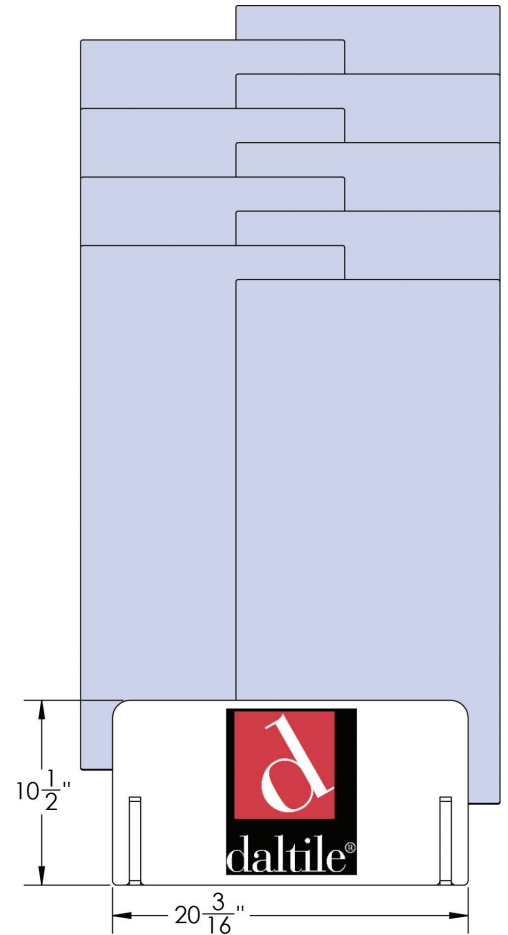
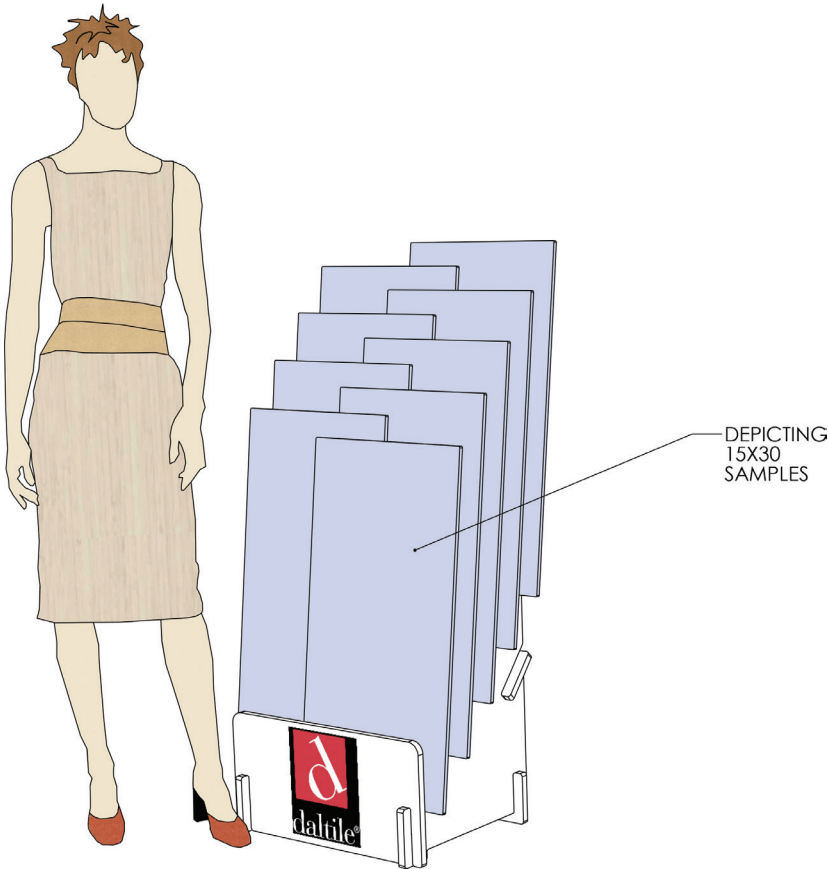

HOLDS (9) SAMPLES THAT ARE MINIMUM 11"
 WIDE (UP TO 1/2" THICK).
 GREAT FOR 12" X 24" AND 15" X 30"
 EASY SLIP TOGETHER ASSEMBLY

WEIGHT 25LBS

MADE WITH THE (MDF) MATERIAL.